

PRODUCT NO.: PT-LB30  
PRODUCT NAME: Micro-Portable LCD Projector

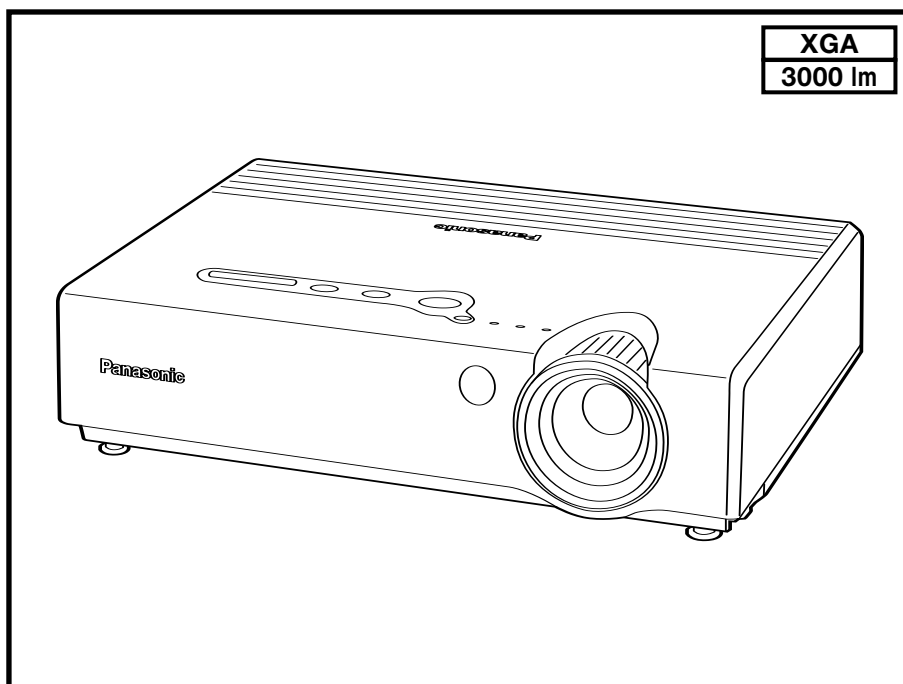

### MAJOR FEATURES

- High power and portability
  - The world's lightest 3,000-lumen projector\*<sup>1</sup>
  - Ultra-lightweight: 2.5 kg/5.5 lbs.
- Daylight View technology
  - A 150% improvement in image performance\*<sup>2</sup>
  - Vivid colors in a bright room
  - Auto operation with ambient light sensor
- Quick operation
  - 2-second speed start
  - One-touch auto setup with digital keystone correction
  - Direct power off

\*<sup>1</sup> As of March 2005

\*<sup>2</sup> Measurements taken at the five main patches of the GretagMacbeth color chart, under typical meeting room light conditions of 400 lux with a screen size of 80 inches.

## Specifications

Power supply		100–240 V AC, 50/60 Hz
Power consumption		300 W (approx. 3 W in standby mode with fan stopped)
Amps		3.5 A–1.8 A
Optical system		Dichroic mirror separation/prism synthesis system
LCD panel	Panel size	0.8" (20.32 mm) diagonal, micro lens array (4:3 aspect ratio)
	Display method	Transparent LCD panel (x 3, R/G/B)
	Drive method	Active matrix
	Pixels	786,432 (1,024 x 768) x 3, total of 2,359,296 pixels
	Pixel configuration	Stripe
Lens		Manual zoom (1:1–1:1.2), manual focus F 1.7–1.8, f 24.0–28.8 mm
Lamp		220 W UHM™ lamp
Colors		Full color (16,777,216 colors)
Brightness		3,000 lumens
Center-to-corner uniformity ratio		90%
Contrast ratio		400:1*1 (full on/full off)
Scanning frequency	RGB	Horizontal: 15–91 kHz, Vertical: 50–85 Hz, Dot clock: less than 100 MHz
	YPbPr	480i (525i): fh 15.75 kHz; fv 60 Hz 576i (625i): fh 15.63 kHz; fv 50 Hz 480p (525p): fh 31.5 kHz; fv 60 Hz 576p (625p): fh 31.25 kHz; fv 50 Hz 720p (750p): fh 45 kHz; fv 60 Hz 1080i (1125i): fh 33.75 kHz; fv 60 Hz 1080i (1125i): fh 28.125 kHz; fv 50 Hz
	S-Video/Video	NTSC, NTSC4.43, PAL-M, PAL60: fh 15.75 kHz; fv 60 Hz PAL, SECAM, PAL-N: fh 15.63 kHz; fv 50 Hz
Projection size		838–7,620 mm (33–300 inches) diagonally, 4:3 aspect ratio
Throw distance		1.1 m–10.8 m (3'7"–35'5")
Optical axis shift		6:1 (fixed)
Keystone correction range		Vertical: approx. ±30°
On-screen menu		17 languages: English, French, German, Spanish, Italian, Korean, Russian, Chinese, Japanese, Swedish, Norwegian, Danish, Portuguese, Polish, Hungarian, Czech, Thai Front/rear, ceiling/desk (menu selection)
Installation		
Built-in speakers	Size	4 x 3 cm x 1, oval
	Output power	1.0 W (monaural)
Terminals	RGB 1 IN	D-sub HD 15-pin x 1
	RGB signal	R, G, B: 0.7 Vp-p, 75Ω Sync on green: 1.0 Vp-p, 75Ω HD/SYNC, VD: TTL (positive/negative polarity compatible)
	YPbPr signal	Y: 1.0 Vp-p (including sync signal), 75Ω Pb, Pr: 0.7 Vp-p, 75Ω
	RGB 2 IN/RGB 1 OUT	D-sub HD 15-pin x 1 (input/output selectable using on-screen menu)
	RGB signal	R, G, B: 0.7 Vp-p, 75Ω Sync on green: 1.0 Vp-p, 75Ω HD/SYNC, VD: TTL (positive/negative polarity compatible)
	YPbPr signal	Y: 1.0 Vp-p (including sync signal), 75Ω Pb, Pr: 0.7 Vp-p, 75Ω
	VIDEO IN	RCA pin x 1, 1.0 Vp-p, 75Ω
	S-VIDEO IN	Mini DIN 4-pin x 1, Y: 1.0 Vp-p, C: 0.286 Vp-p, 75Ω
	AUDIO IN	RCA (L, R) x 1, 0.5 Vrms (for VIDEO/S-VIDEO)
	RGB AUDIO IN	M3 (L, R) x 2, 0.5 Vrms
	AUDIO OUT	M3 (L, R) x 1, 0–1.0 Vrms (variable)
	SERIAL	Mini DIN 8-pin x 1 (RS-232C)

Power cord length		2 m/6.6'
Cabinet material		Moulded plastic (ABS/PC)
Dimensions (W x H x D)		327 x 75.8 x 233 mm (12-27/32. x 2-31/32. x 9-5/32")
Weight		2.5 kg (5.5 lbs.)
Operating environment	Temperature	0° – 40°C (32°–104°F)
	Humidity	20%–80% (no condensation)
Remote control unit	Power supply	3 V DC (button battery x 1)
	Operation range*2	Approx. 7 m when operated from directly in front of the signal receptor
	Dimensions (W x H x D)	40 x 86 x 6.5 mm (1-9/16" x 3-3/8" x 1/4")
	Weight	18 g (0.6 oz.) (including a battery)
Supplied accessories		Power cord
		Card remote control
		Lithium button battery for remote control
		RGB signal cable
		Carrying bag
		Software CD-ROM
Optional accessories		Replacement lamp unit: ET-LAB30
		Ceiling mount bracket: ET-PKB30
		Full-function wireless remote control: ET-RM300
		Serial adapter (DIN 8-pin/D-sub 9-pin): ET-ADSER

\*1: In AI mode.

\*2: Operation range differs depending on environments.

Weights and dimensions shown are approximate.  
Specifications subject to change without notice.

Micro-Portable LCD Projector

PT-LB30

Dimensions

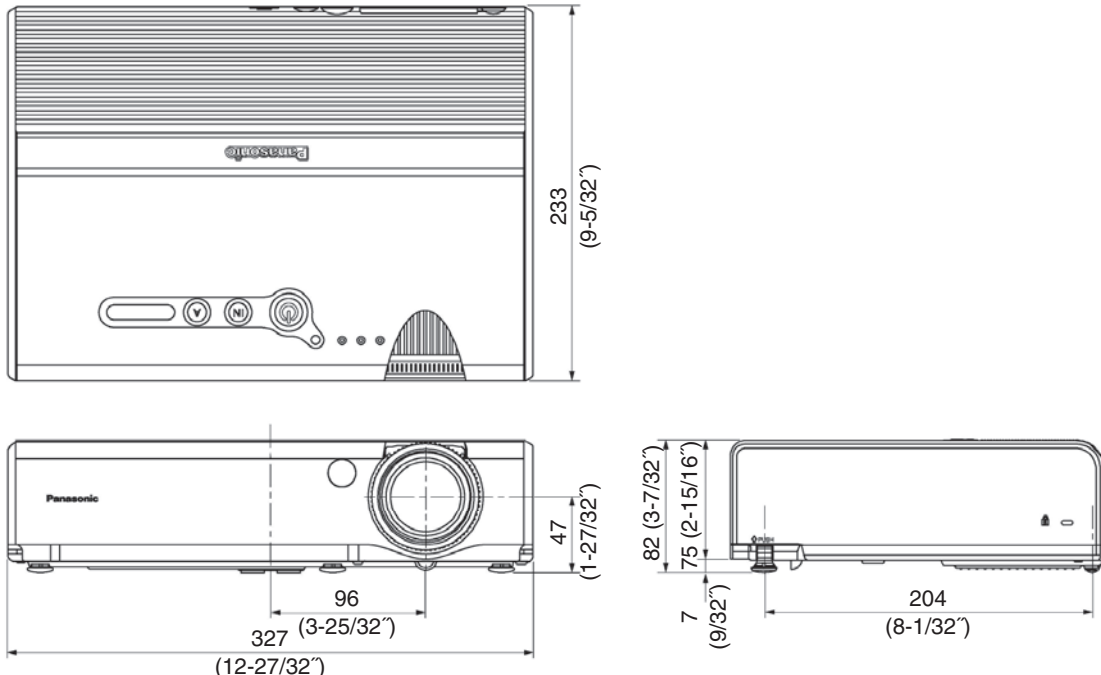

unit: mm (inch)

Note: This illustration is not drawn to scale.

Terminals

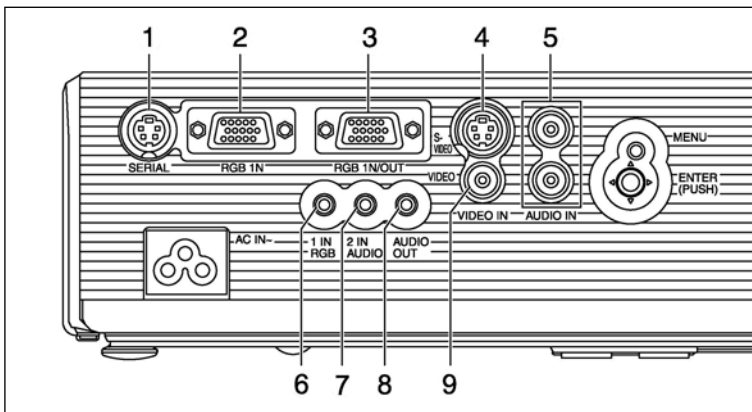

- 1 Serial
- 2 RGB 1 input
- 3 RGB 2 input/RGB 1 output
- 4 S-Video input
- 5 Audio input for Video/S-Video
- 6 Audio input for RGB 1
- 7 Audio input for RGB 2
- 8 Audio output
- 9 Video input

RGB IN connector pin assignment

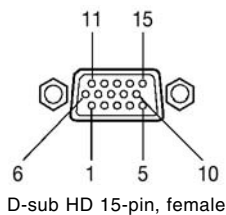

no.	signal	no.	signal	no.	signal
1	R/PR	6	GND	11	GND
2	G/Y	7	GND	12	SDA*
3	B/PB	8	GND	13	HD/SYNC
4	NC	9	NC	14	VD
5	GND	10	GND	15	SCL*

\* Effective when connected to a PC having proper functions.

Standard setting-up positions

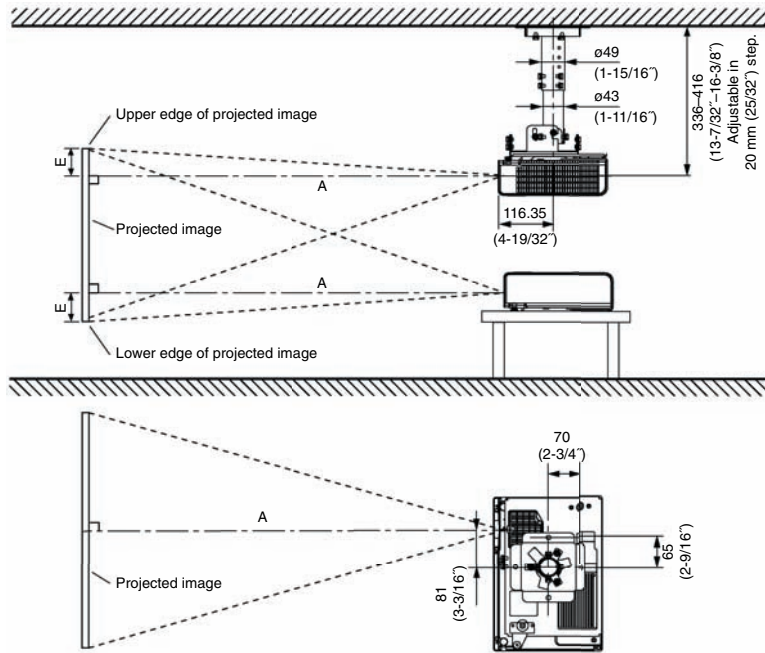

unit: mm (inch)

A: Distance to screen  
E: Height from the edge of screen to center of lens

NOTE:  
Illustrations show the projector installed using optional ceiling bracket.  
This illustration is not drawn to scale.

Diagonal image size (4:3 aspect ratio)	Distance to screen		Height from the edge of screen to center of lens
	min.	max.	
33" / 0.84 m / 2.7'	-	1.1 m / 3.6'	7 cm / 2.8"
40" / 1.02 m / 3.3'	1.2 m / 3.9'	1.4 m / 4.6'	8 cm / 3.1"
50" / 1.27 m / 4.2'	1.5 m / 4.9'	1.7 m / 5.6'	11 cm / 4.3"
60" / 1.52 m / 4.9'	1.8 m / 5.9'	2.1 m / 6.9'	13 cm / 5.1"
70" / 1.78 m / 5.8'	2.1 m / 6.9'	2.5 m / 8.5'	15 cm / 6.3"
80" / 2.03 m / 6.7'	2.4 m / 7.9'	2.8 m / 9.2'	17 cm / 6.7"
90" / 2.29 m / 7.5'	2.7 m / 8.9'	3.2 m / 10.5'	19 cm / 7.5"
100" / 2.54 m / 8.3'	3.0 m / 9.8'	3.5 m / 11.5'	21 cm / 8.3"
120" / 3.05 m / 10.0'	3.6 m / 11.8'	4.3 m / 14.1'	25 cm / 9.8"
150" / 3.81 m / 12.5'	4.6 m / 15.1'	5.4 m / 17.7'	32 cm / 12.6"
200" / 5.08 m / 16.7'	6.1 m / 20.0'	7.2 m / 23.6'	42 cm / 16.5"
250" / 6.35 m / 20.8'	7.6 m / 24.9'	9.0 m / 29.5'	53 cm / 20.9"
300" / 7.62 m / 25.0'	9.1 m / 29.9'	10.8 m / 35.4'	63 cm / 24.8"

NOTE:  
Values shown are approximate.

Calculation of the projection distance

For a screen size different from the above, use the equation below to calculate the projection distance.

Aspect ratio 4 : 3

minimum L (m) = (diagonal screen size in inches) x 0.0303 - 0.044  
 maximum L (m) = (diagonal screen size in inches) x 0.0364 - 0.044

Aspect ratio 16 : 9

minimum L (m) = (diagonal screen size in inches) x 0.0331 - 0.044  
 maximum L (m) = (diagonal screen size in inches) x 0.0397 - 0.044

Computer data compatibility

This projector accepts up to 91 kHz horizontal scanning frequency and 162 MHz dot clock.

NOTE: The projector is not fully compatible with RGB signals of which dot clock is higher than 100 MHz.  
 The display resolution of this projector is 1024 x 768 pixels. If the display resolution indicated in the above data does not match this resolution, the input signal will be converted to 1024 x 768 pixels.