

# Imaginex Series

WTIW77 interactive whiteboard and WT610E projector bundle  
ideal for educational environments

Revolutionize the classroom by getting students more involved with day-to-day materials. By utilizing a PC or Mac and a projector, the power of this teaching tool will increase students' attention and retention.

## FEATURES AND FUNCTIONS

- **Complete compatibility.** Ships with the NEC WT610E DLP projector, IW77 interactive whiteboard and WT60WM wall mount.
- **Annotation tools** include pen, shapes, highlighter, eraser, redo/undo and save buttons allowing users to create endless possibilities on the screen. Teach everything from handwriting to music all on the board and be able to save files for students to take home.
- **Web collaboration.** Broadcast and share material over an intranet or the Internet. The host broadcasts the material over a network and participants log in to see notes and annotations in real-time.
- **Mouse functionality** allows the user to control the desktop from the board with the included stylus pen. Open files, browse the internet and much more.
- **Present almost instantly.** PowerPoint button brings up a File > Open window that allows the user to quickly open up PowerPoint files in Slideshow mode.
- **Three different interactive tools** to choose from:
  - **SCRAPBOOK application.** The scrapbook turns the image on the whiteboard surface into a digital workspace. Multiple tools within the application allow the user to record notes digitally, import screen shots and other files as background images, save scrapbook files and use layers to hide and show elements of a page
  - **Desktop palette.** Allows quick selection of major functions including annotation, pop-up keyboard.
  - **PowerPoint palette.** Allows annotation and navigation from slide presentations.
- **Durable surface.** Specially researched and developed porcelain enamel skin from Alfher Porcewol combine to withstand almost any common usage damage to the surface.

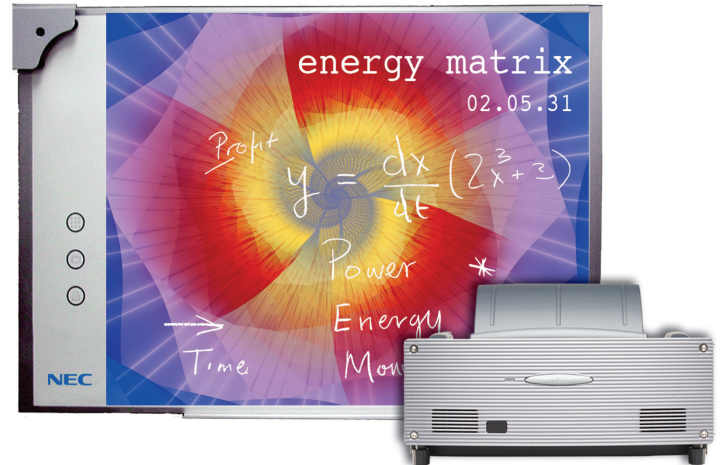

INTERACTIVE TECHNOLOGY ENABLES CONTROL OF COMPUTER AND COURSE CONTENT

INVOLVES STUDENTS IN SUBJECT MATTER PROMOTING INCREASED SUBJECT RETENTION

NEWPROJECTS AND EDITS TO EXISTING MATERIALS CAN BE SAVED FOR FUTURE REVIEW

WHITEBOARD INCLUDES MOUNTING HARDWARE, INTERACTIVE DIGITAL STYLUS AND SOFTWARE

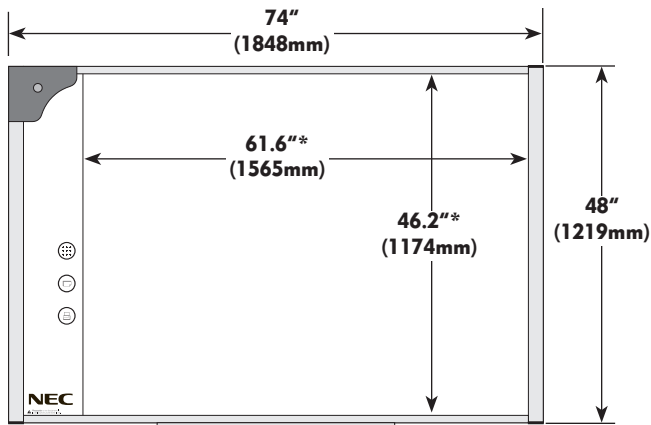

\* WRITING SURFACE DIMENSIONS



### Specifications for WTIW77

Display Aspect Ratio	4:3
Inputs	Infrared and ultrasonic
Computer Interface	USB 2.0
Screen Size	
Diagonal	77 in. / 1956mm
W x H	61.6 x 46.2 in. / 1565 x 1174mm
Positional Accuracy	+/- 1.5mm
<b>MECHANICAL</b>	
Overall Dimensions (W x H x D)	74x48x2 in. / 1848x1219x50.8mm
Weight	
Net	63 lbs.
Gross	77 lbs.
<b>ENVIRONMENTAL</b>	
Operating Temperature	16 - 32°C
Humidity	40 - 70%
<b>BUNDLED SOFTWARE*</b>	Interactive software providing organization for gathering, preparing, presenting and sharing computer content. Handwriting recognition provided via Microsoft Office software
<b>MINIMUM SYSTEM REQUIREMENTS</b>	
Windows	Pentium IV, 512MB RAM, 20 MB available HD space; Windows XP, 2000, 2003, Vista, and Tablet PC
Macintosh	Mac OS X 10.4 and higher Available USB port
<b>WARRANTY</b>	Two-year limited warranty on hardware and software
<b>ACCESSORIES</b>	
IWSTYLUS	Replacement stylus

\* Macintosh software available for download at [www.necdisplay.com](http://www.necdisplay.com)

### Specifications for WT610E

<b>OPTICAL</b>	Display Technology Resolution Native Maximum Light Output (lumens) Contrast Ratio Lamp Type Lamp Life (up to) Screen Size (diagonal) Projection Distance Projection Angle Keystone Correction	Single chip 12 degree DMD  XGA 1024 x 768 UXGA 1600 x 1200 2000 normal / 1500 eco 3500:1 275W DC 2000 hours normal / 4000 hours eco 40-100 in. 2.5 - 25.9 in. / 64 - 659mm 55° ±5° Horizontal and -5° Vertical
<b>SIGNAL COMPATIBILITY/CONNECTIVITY</b>	Scan Rate  Supported Video Standards  SD/HD Video Signal Compatibility PC Signal Compatibility Macintosh Compatibility Input/Output Terminals RGB 1 (analog) RGB2 (analog) Video 1 Video 2 Audio Audio Out Monitor Out Audio External Control Sync Compatibility Networking	Horizontal 15 - 100 kHz (non-interlaced) / Vertical 50 - 120 Hz NTSC, NTSC4.43, PAL, PAL-60, PAL-M, PAL-N, SECAM 1080i, 720p, 576p, 576i, 480p, 480i VGA, SVGA, XGA, SXGA, SXGA+, UXGA Yes  15 pin DVI-I with HDCP Composite S-Video 1 set RCA, 2 stereo mini Variable audio out Yes 1W x 2 RS232, LAN (AMX/Crestron compatibility), remote in Separate Sync / Composite Sync / Sync on G Wired LAN using integrated RJ45, 802.11b/g wireless with optional card
<b>ELECTRICAL</b>	Power Req. Input Current Power Consumption	100-120VAC/200-240VAC, 50/60Hz 3.9A (100V), 1.7A (240V) Eco-Mode 300W, Normal 370W, 0.6W Standby, 8.0W Idle Mode
<b>MECHANICAL</b>	Installation Orientation Dimensions (WxDxH)  Net Weight Fan Noise Regulations	Floor/Front, Floor/Rear, Ceiling/Front, Ceiling/Rear 14.96x12.32x12.32 in. / 380x313x313mm, mirror open (not including protrusions) 14.1 lb. / 6.4 kg < 37 dB normal / 32 dB eco USA UL 1950 FCC Class B, Canada CSA950 (C-UL), NOM
<b>ENVIRONMENTAL</b>	Operational Temp Humidity Storage	41° - 95°F / 5° - 35°C 20-80% non-condensing 14° - 122°F / -10° - 50°C
<b>WARRANTY</b>	Owners receive a 2-year limited parts and labor warranty. RepairCare™ is provided during the first year of coverage for registered owners. RepairCare provides the original owner with 3-business day repair and return of the projector. When used under normal operating conditions, the lamp is covered for 90 days or 500 hours, whichever comes first.	
<b>ACCESSORIES</b>	Order Code WT61LP NWL-100A WTPL-01	Description Replacement lamp 802.11b/g wireless LAN PC card Extends term of limited parts and labor warranty to three years

Additional accessories are available, including screens, carts, mount accessories and replacement cables. Visit [www.necdisplay.com](http://www.necdisplay.com) for details.



DLP and the DLP logo are registered trademarks of Texas Instruments. All other brand or product names are trademarks or registered trademarks of their respective holders. Product specifications subject to change. 8/07 ver. 1.  
 ©2007 NEC Display Solutions of America, Inc. All rights reserved.

**NEC Display Solutions**  
 500 Park Boulevard, Suite 1100  
 Itasca, IL 60143  
 866-NEC-INFO

**NEC**